

groov EPIC POWER SUPPLIES, CONVERTERS, AND ADAPTERS

Features

- > Built-in fuse and ON/OFF power switch
- > Designed to integrate tightly with *groov* EPIC® processor and chassis
- > Wide input voltage ranges
- > UL Hazardous Locations approved and ATEX compliant

DESCRIPTION

groov® EPIC power supplies, converters, and adapters provide AC or DC options to power your Opto 22 *groov* EPIC system. Packaged in a modern and sturdy housing, *groov* EPIC power supplies include a built-in fuse and an ON/OFF power switch for ease of use.

The **GRV-EPIC-PSAC** power supply and the **GRV-EPIC-PSDC** voltage converter are designed to provide power for a *groov* EPIC chassis with a GRV-EPIC-PR1 processor, and *groov* I/O modules mounted on the chassis. The combination of a chassis, processor, and modules is called an *I/O unit*.

The **GRV-EPIC-PSPT** pass-through power adapter is designed to allow you to connect a user-supplied, external 12 V power supply to the *I/O unit*.

All *groov* power supplies, voltage converters, and adapters are UL/cUL listed and compliant with the ATEX, Low Voltage, and EMC CE directives.



GRV-EPIC-PSAC power supply



GRV-EPIC-PSDC power supply



Part Numbers

Part	Description
GRV-EPIC-PSAC	Power supply, 110–240 VAC
GRV-EPIC-PSDC	Power converter, 24–48 VDC
GRV-EPIC-PSPT	Pass-through power adapter, 10–15 VDC



SPECIFICATION

Specification	GRV-EPIC-PSAC	GRV-EPIC-PSDC	GRV-EPIC-PSPT
Max Output Power	60 W (-20 °C ≤ T _a ≤ 50 °C) 50 W (50 °C < T _a ≤ 70 °C)	50 W (-20 °C ≤ T _a ≤ 70 °C)	108 W from external 12 VDC supply, (-20 °C ≤ T _a ≤ 70 °C)
Input Voltage Range	110 to 240 VAC nominal, 100 to 264 VAC max.	24 to 48 VDC nominal, 22 to 50 VDC max.	10 to 15 VDC
Typical Input Current (max load)	0.6 A at 115 VAC	3.5 A at 22 VDC	9 A at 12 VDC
Inrush Current	30 A at 115 VAC	2.5 I ² t (A ² s)	2.5 I ² t (A ² s)
Input Frequency Range	50 Hz to 60 Hz	n/a	n/a
Power Factor	>0.98 at 115 VAC, full load	n/a	n/a
Wire size	28–12 AWG	28–12 AWG	28–12 AWG
Torque (connector screw)	4.4 in-lb	4.4 in-lb	4.4 in-lb
Fuse	2 A 250 V Slow Opto 22 PN: GRV-EPIC-PSAC-FUSE	4 A 250 V Slow Opto 22 PN: GRV-EPIC-PSDC-FUSE	10 A 125 V Fast Opto 22 PN: GRV-EPIC-PSPT-FUSE
Operating Ambient Temperature	-20 °C to 70 °C	-20 °C to 70 °C	-20 °C to 70 °C
Altitude Temperature Derating	5 °C per 1000 m over 2000 m	5 °C per 1000 m over 2000 m	n/a
MTTF (minimum, 25 °C)	650 khrs	4.5 Mhrs	4.5 Mhrs
Agency Approvals	UL/cUL(Class 1 Div. 2), CE, ATEX(Category 3, Zone 2), RoHS, DFARS		
Warranty	30 months	30 months	30 months



MOUNTING

In the following instructions, the *groov* EPIC power supply, adapter, or converter is referred to as “power supply”.

1. Orient the *groov* EPIC chassis so that the module connector numbers are right-side up, with zero on the left, as shown in the diagram below.
2. Hold the power supply at a 45° angle, with the tabs at the back of the supply aligned with the notches on the chassis.
3. Lower the front-end of the supply onto the chassis until you feel the plug snap into the slot.
4. Following the wiring guidelines in “Power Supply Guidelines and Wiring” on page 4 to connect the power source to the power wiring connector of the *groov* EPIC power supply.

Note: To make it easier to connect the power supply wires, you can remove the power wiring connector from the power supply by loosening the screws on either side of the connector. See diagram at the bottom of the page.

5. Secure the connections by tightening the screws on the power wiring connector.

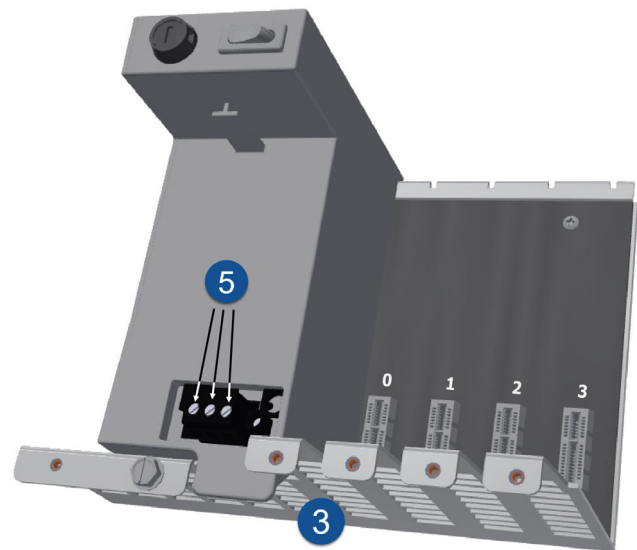
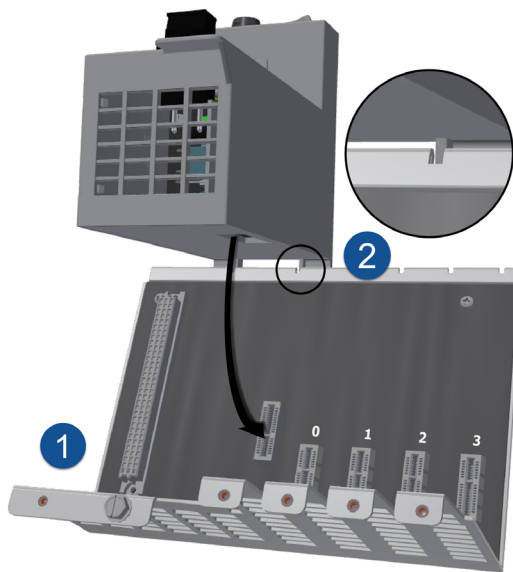

REMOVING THE POWER SUPPLY, CONVERTER, OR ADAPTER

1. Turn off the power switch.
2. Remove the processor according to the instructions in the *groov* EPIC Processor Data Sheet (form 2245). Do not attempt to remove the processor and the power supply as a single unit.
3. Loosen the screws of the power wiring connector (as shown in the diagram on the right) and remove the connector from the power supply.
4. Hold the top of the power supply with one hand, then using the thumb of your other hand, lift the front of the power supply by the lip.
5. Pivot the lip up to disconnect the power supply from the chassis.
6. Remove the power supply from the chassis by lifting it up and off the top of the chassis.

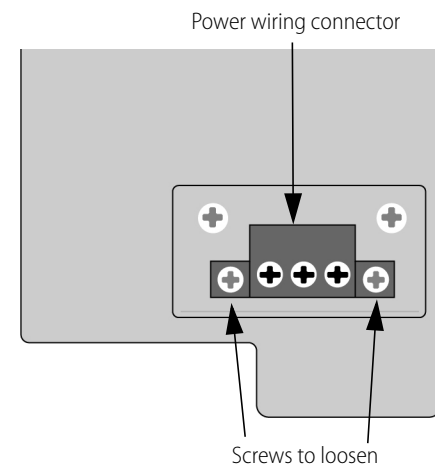

POWER SUPPLY GUIDELINES AND WIRING

Always use a separate field supply

Use a separate power supply for the field side of the I/O. Using the chassis supply for field actuation and monitoring defeats the isolation the I/O modules offer and therefore increases the chance of a ground loop within the control system. Additionally, fluctuations on the field side can cause undesirable voltage fluctuations that may interfere with the processor's operation.

Some modules (for example, the GRV-OVMALC-8) provide their own isolated, regulated, field-side power supply.

Power Wiring Diagrams

Before wiring the GRV-EPIC-PSAC, GRV-EPIC-PSDC or GRV-EPIC-PSPT, verify that your wiring cables conform to the requirements described above.

Power wiring guidelines

Opto 22 recommends you follow these wiring guidelines:

Use a mains-isolated 24 to 48 VDC power source or supply to feed the GRV-EPIC-PSDC.

Use the appropriate gage wire:

- For GRV-EPIC-PSDC or GRV-EPIC-PSPT with DC input, use 16 to 12 AWG. Keep the wires as short as possible.
- For GRV-EPIC-PSAC, use 18 to 12 AWG . Keep the wires as short as possible.

GRV-EPIC-PSAC

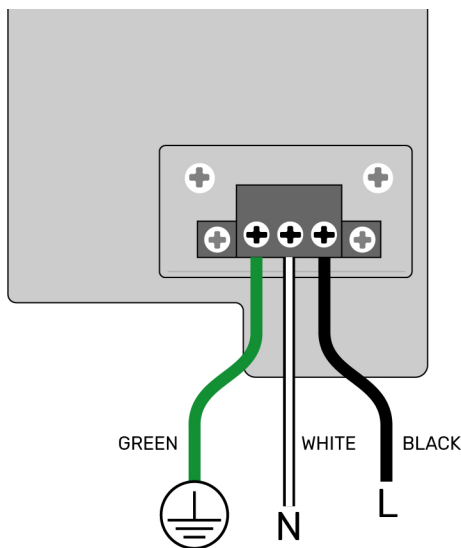

GRV-EPIC-PSDC, GRV-EPIC-PSPT

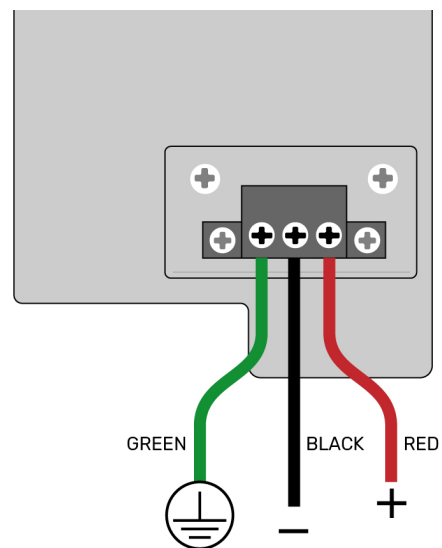

DIMENSIONS: GRV-EPIC-PSAC, GRV-EPIC-PSDC, AND GRV-EPIC-PSPT

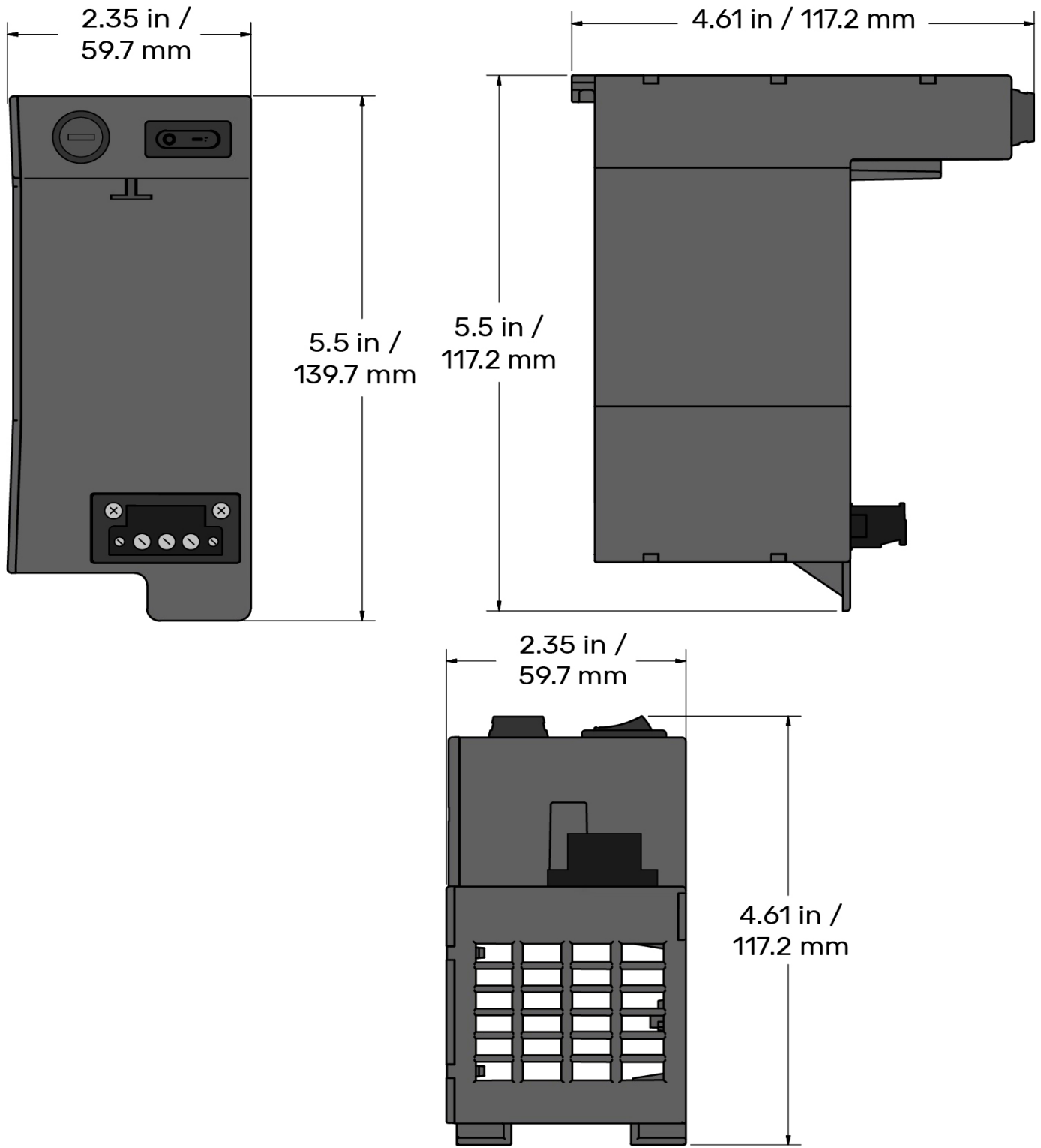

CALCULATING POWER REQUIREMENTS

The GRV-EPIC-PSAC power supply is limited to 60 W and the GRV-EPIC-PSDC power converter is limited to 50 W. To verify that you do not exceed these ratings—particularly when you are installing GRV-OVMALC-8 and GRV-OVMAILP-8 modules—fill out this worksheet (one per chassis; both sides) to calculate how much power your unit will require with the modules you selected.

Item	Quantity	x Power Req (W)	Total Power Req (W)
<i>groov</i> EPIC PR1 processor (GRV-EPIC-PR1)		7.1	
GRV-CSERI-4 serial input module		1.5	
GRV-IAC-24 analog input module		1.0	
GRV-IACDCTTL-24 analog input module		1.0	
GRV-IACDCTTLS-24 analog input module		1.0	
GRV-IACHV-24 analog input module		1.0	
GRV-IACHVS-24 analog input module		1.0	
GRV-IACI-12 analog input module		1.0	
GRV-IACIHV-12 analog input module		1.0	
GRV-IACIHVS-12 analog input module		1.0	
GRV-IACIS-12 analog input module		1.0	
GRV-IACS-24 analog input module		1.0	
GRV-IDC-24 DC input module		1.2	
GRV-IDCI-12 DC input module		1.2	
GRV-IDCIFQ-12 DC input module		1.0	
GRV-IDCIS-12 DC input module		1.2	
GRV-IDCS-24 DC input module		1.2	
GRV-IDCSW-12 DC input module		2.4	
GRV-IICTD-12 analog input module		1.0	
GRV-IMA-24 analog input module		1.0	
GRV-IMAI-8 analog input module		1.4	
GRV-IRTD-8 analog input module		1.3	
GRV-ITM-12 analog input module		1.3	
GRV-ITMI-8 analog input module		1.4	
GRV-ITR-12 analog input module		1.3	
GRV-IV-24 analog input module		1.0	
GRV-IVI-12 analog input module		2.2	
GRV-OAC-12 analog output module		1.3	
GRV-OACI-12 analog output module		1.3	
GRV-OACIS-12 analog output module		1.3	
GRV-OACS-12 analog output module		1.3	
GRV-ODCI-12 DC output module		1.2	
GRV-ODCIS-12 DC output module		1.2	
GRV-ODCSRC-24 DC output module		1.2	
GRV-OMRIS-8 analog output module		1.4	



Item	Quantity	x Power Req (W)	Total Power Req (W)
GRV-OVMAILP-8 analog output module (all voltage outputs)		1.8	
GRV-OVMAILP-8 analog output module (all current outputs)		6.0	
GRV-OVMALC-8 analog output module (all voltage outputs)		1.8	
GRV-OVMALC-8 analog output module (all current outputs)		6.2	
Total			



PRODUCTS

Opto 22 develops and manufactures reliable, easy-to-use, open standards-based hardware and software products.

Industrial automation, process control, building automation, industrial refrigeration, remote monitoring, data acquisition, and industrial internet of things (IIoT) applications worldwide all rely on Opto 22.

groov EPIC® System

Opto 22's *groov* Edge Programmable Industrial Controller (EPIC) system is the culmination of over 40 years of experience in designing products for the automation industry.

groov EPIC gives you an industrially hardened system with guaranteed-for-life I/O, a flexible Linux®-based processor with gateway functions, and software that meets the needs of your automation and IIoT applications.

groov EPIC I/O

I/O provides the local connection to sensors and equipment. *groov* I/O offers up to 24 channels on each I/O module, with a spring-clamp terminal strip, integrated wireway, swing-away cover, and LEDs indicating module health and digital channel status.

groov I/O is hot swappable, UL Hazardous Locations approved, and ATEX compliant. Opto 22 I/O is so reliable, we guarantee it for life.

groov EPIC Processor

The heart of the system is the *groov* EPIC processor. It handles a wide range of digital, analog, and serial functions for data collection, remote monitoring, process control, and discrete and hybrid manufacturing.

In addition, the EPIC provides secure data communications among physical assets, control systems, software applications, online services, and more, both on premises and in the cloud.

Configuring and troubleshooting I/O and networking is easier with the EPIC's integrated high-resolution color touchscreen. Authorized users can manage the system locally on the touchscreen or on a monitor connected via the HDMI or USB ports.

groov EPIC Software

Software included in the *groov* EPIC controller:

- PAC Control engine to run PAC Control strategies and PAC Display projects
- CODESYS Runtime engine to run IEC61131-3 compliant programs built with CODESYS Development System

Optional access to the Linux operating system through a secure shell (SSH) to download and run custom applications

groov View for building your own device-independent HMI, viewable on the touchscreen, PCs, and mobile devices.

Node-RED for creating simple logic flows from pre-built nodes
Ignition Edge® from Inductive Automation®, with OPC-UA drivers to Allen-Bradley®, Siemens®, and other control systems, and MQTT/Sparkplug communications for efficient IIoT data transfer

Older products

From solid state relays (our first products) to world-famous G4 and SNAP I/O, to SNAP PAC controllers, older Opto 22 products are still supported and still doing the job at thousands of installations worldwide. You can count on us to give you the reliability and service you expect, now and in the future.



QUALITY

Founded in 1974, Opto 22 has established a worldwide reputation for high-quality products. All are made in the U.S.A. at our manufacturing facility in Temecula, California.

Because we test each product twice before it leaves our factory rather than testing a sample of each batch, we can afford to guarantee most solid-state relays and optically isolated I/O modules for life.

